

VAV Airflow Control – Reliable Without Limitations?

Ron Simens

Facility Dynamics Engineering

Synopsis

Pressure independent, variable air volume (VAV) systems are common in the world of modern HVAC. In the author's experience, it is common for testing, adjusting, balancing (TAB) and building automation system (BAS) personnel to make large leaps of faith regarding individual VAV operation. Much, if not most, Building Automation System (BAS) zone control software currently utilize a single point of calibration (Correlation of a field measured airflow with VAV inlet sensor ΔP measured by BAS). This approach assumes the relationship of airflow to ΔP is directly proportional throughout the entire VAV operational range. Inherent in this assumption is another; whatever error may exist between apparent and actual airflow throughout the range of operation by an individual VAV, it is small enough to be insignificant.

On multiple occasions over his career, the author has observed airflow and VAV inlet sensor ΔP which correlates perfectly at the calibrated point of operation (Typically Maximum airflow mode of operation) but differs considerably at other points. When manifested, this discrepancy can result in significant energy waste and a lack of zone ventilation airflow. This paper documents several experiences when the author observed significant variance of actual VAV performance when compared with manufacturer data, TAB reports, and/or BAS displayed airflow. Also addressed are several methods of appropriate investigation as well as suggested future action.

About the Author

Ron Simens began his career in HVAC as a Testing, Adjusting & Balance (TAB) technician. In this capacity, Ron worked on the Central Coast of California in many large pharmaceutical, biotechnology and semiconductor research/development and production facilities for 15 years. For the next 5 years, Ron managed the TAB department of a large Design/Build Mechanical Contractor in the Silicon Valley of California. In this capacity, Ron interacted extensively with the Engineering Department, affording him an opportunity to gain a deeper understanding of fluid dynamics and thermodynamics than had been possible working in the field.

In 2007, Ron accepted the position of Mechanical Engineer at Facility Dynamics Engineering where he is currently employed. Ron works on FDE projects across the nation performing Cx, RCx as well as a considerable amount of forensic engineering on BAS and MEP systems.

Ron received a BA in Labor Education and multiple related certifications from Testing, Adjusting and Balancing Bureau (TABBB), National Environmental Balancing Bureau (NEBB) and NSF International. Ron spent 10 years teaching apprentice classes through Foothill College in Los Altos Hills, CA as well as teaching national "Train-the-trainer" classes for TABBB.

Section 1 – Introduction

Familiarity often leads to complacency which is often followed closely by assumption. Pressure independent VAVs are common components of modern HVAC systems. As a result, many Testing, Adjusting, Balancing (TAB) and Building Automation System (BAS) engineers/technicians seem to assume direct digital controlled (DDC) VAVs are “plug-and-play,” requiring little attention past a brief airflow calibration. Successful completion of the VAV system installation, start-up and balance process to TAB and BAS personnel often appears considered met if design airflow at Maximum, and sometimes Minimum airflow, has been achieved. The practical goal (Satisfying zone design parameters while ensuring occupant comfort or successful process operations simultaneously using the least amount of energy and ensuring stable operation of the entire system) is frequently ignored or completely forgotten.

While there is much to analyze and discuss within the general and extremely broad topic of VAV design, application and performance, this paper will focus on airflow measurement and control at the VAV inlet duct airflow sensor. The order of this discussion is as follows:

- VAV Airflow Measurement
- VAV Airflow Testing
- Example from Medical Research Facility RCx
- Addressing VAV Calibration Issues

This paper assumes a rudimentary understanding of VAV operation by the reader. Consequently, airflow measurement, control and VAV system requirements are mentioned merely in passing.

It is important for the reader to understand that the contents of this paper are the results of many years of VAV operational observations performed in concert with considerable field testing experience. The precise extents of the variables discussed in this paper have NOT been verified during scientific analysis and testing performed in an exacting laboratory environment. Anomalies in VAV operation presenting themselves on random occasions have simply been measured and documented with circumstances appearing to form patterns described in this paper.

The intent of this paper is to focus interest and attention to this issue that does not appear to concern many participants in the fast-paced world of HVAC design, installation, start-up and calibration but inevitably occurs and remains unaddressed for the life of a system or building.

Section 2 – VAV Airflow Measurement

While there are many forms of VAV airflow measurement that have been and are currently used, most VAVs utilize a form of differential pressure (ΔP) measured by a sensor installed in the inlet duct of the VAV. The precise location and configuration of airflow sensing devices varies between VAV manufacturers.

Airflow Measurement Method

The basic principle of differential pressure measurement on a VAV airflow sensor is similar to the use of a Pitot tube as demonstrated in **Figure 1**.

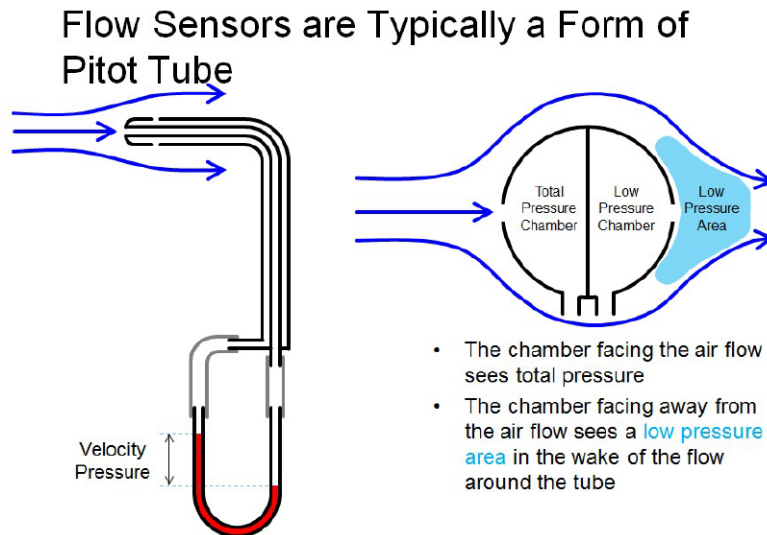

Figure 1: Pitot Tube & VAV Airflow Sensor Comparison (Sellers)

Both technically and mathematically it is incorrect to refer to the VAV airflow sensor measurement as Velocity Pressure. The “low pressure area” is a pressure lower than the Static Pressure in the duct which means that the difference between Total Pressure and this “Low Pressure” is larger or amplified beyond the differential pressure of Total Pressure and Static Pressure. VAV manufacturers refer this measurement as Differential Pressure or simply ΔP .

Differential Pressure Sensor Variations

The precise shape of airflow measurement sensors vary significantly between VAV manufacturers. All seem to be effective to some degree. Some of the most common depicted in **Figure 2** are a front and rear view of the “X” style sensor, circular sensors and single “bar type” sensors extending horizontally across the duct with single or multiple “Hi” or Total Pressure (TP) ports. The number of sensed TP ports on the “Bar type” is dependent on the duct width and the individual sensor manufacturer.

The interior of the “Hi” sensor is a common chamber, averaging all of the Total Pressure measurements while the interior of the “Low” sensor, also a common chamber, averages all Static Pressure measurements. The resulting “average” ΔP is what is measured by the DDC VAV differential pressure transducer (DPT).

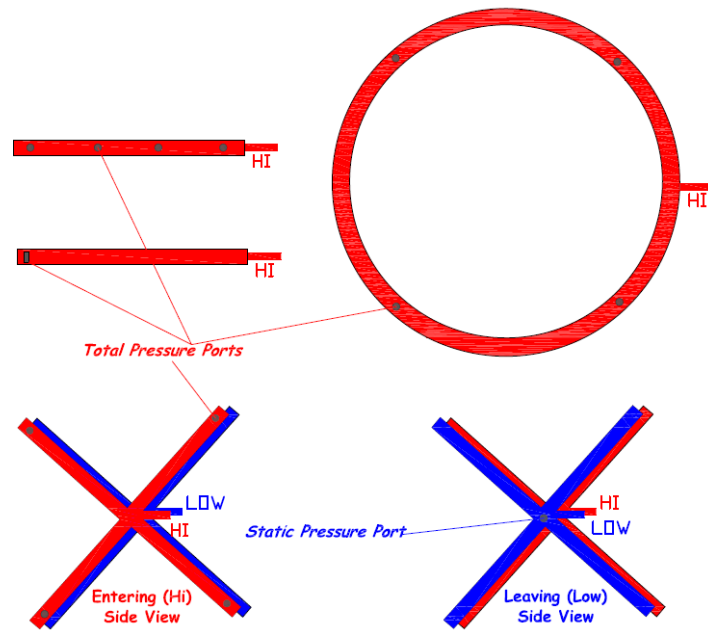

Figure 2: Variations of VAV Inlet Flow Sensors.

Section 3 – VAV Airflow Testing

VAV manufacturers typically attach variations of the **Figure 3** chart depicting ΔP versus airflow in CFM to each terminal unit. These charts are also published in VAV literature.

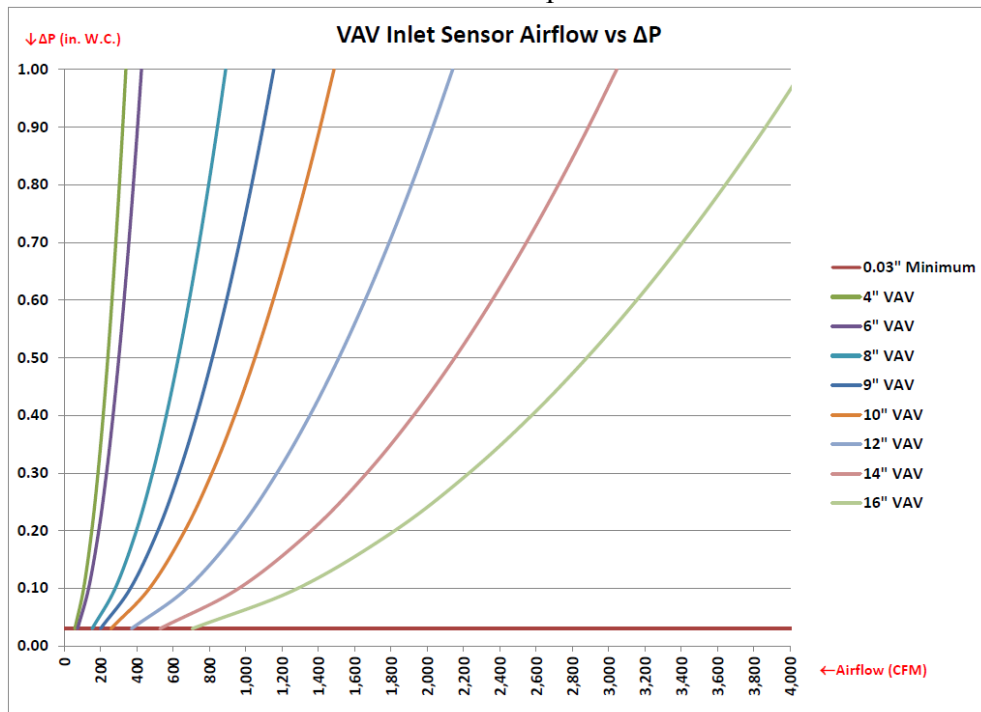

Figure 3: Typical VAV Sensor Airflow vs ΔP Chart.

During recent correspondence regarding the methodology and VAV system testing configuration for generating their versions of **Figure 3**, VAV manufacturers referred to *ASHRAE Standard 130-2008, Methods of Testing Air Terminal Units*. Specifically mentioned in these correspondences are Sections 5.6, “Airflow Sensor Performance-Straight Duct Conditions” and 5.7, “Airflow Sensor Performance-Inlet & Outlet Duct Variations”.

Factory Testing

Prior to the *ASHRAE Standard 130-2008*, VAV manufacturers developed the airflow performance chart with a testing system composed of a VFD controlled fan, an airflow station with a long length of straight duct both before and after the station and a VAV terminal unit WITHOUT a modulating damper as in **Figure 4**. Several manufacturers have informed me in recent correspondence that this component arrangement is still in use without variation. *ASHRAE 130-2008, paragraph 5.6.1* states, “This test is intended to measure terminal unit air flow sensor output at various airflows (or velocities) for a specified duct static pressure. Its purpose is to determine the effects of the throttling device on flow sensor performance.”

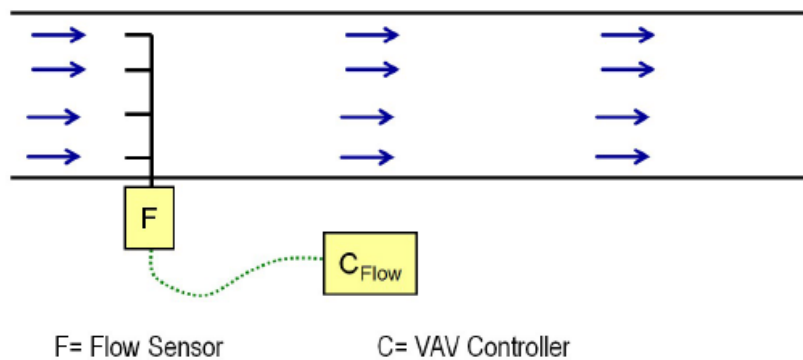

Figure 4: VAV Configuration at VAV Manufacturer Facility

Questions regarding this apparent anomaly between published data, current testing components in their facilities and the *ASHRAE Standard 130-2008, Section 5.6* have yet to receive response. Literature and web searches of several VAV manufacturer’s sites have not revealed further information regarding *ASHRAE 130-2008, Section 5.6* testing.

Field Testing

Field testing and calibration of individual VAV terminal units is typically performed under conditions which can vary considerably from those encountered in the factory environment. **Figure 5** depicts a VAV with a damper 100% open. The very small dynamic ripple caused by a completely open damper and most other installed duct components does not appear to affect the VAV airflow sensor measurement significantly. It has been my experience that VAVs control airflow remarkably well if they have been calibrated under conditions that resemble the conditions where they are expected to operate during their use.

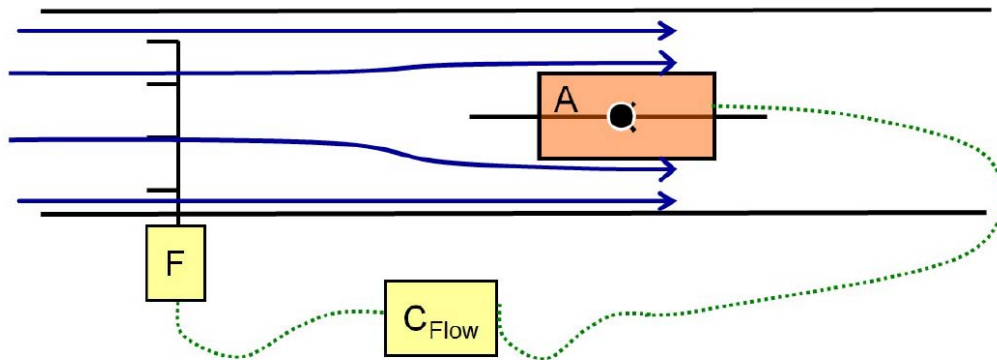

Figure 5: VAV Configuration in Field with Damper 100% Open (Sellers)

Field Testing Experiences

Airflow Sensor DP versus Actual Measured Airflow – On multiple occasions as a TAB professional I attempted to utilize VAV manufacturer airflow charts in one manner or another to assist me. This involved measuring sensor ΔP with a calibrated instrument in parallel with the BAS. The measured ΔP was compared to the VAV airflow chart to determine the approximate airflow. VAV manufacturer literature provides precise mathematical formulas and factors to convert sensor ΔP measurement into airflow expressed in CFM. The results of these efforts were typically inconsistent, particularly when attempting to convert Minimum ΔP to accurate CFM.

VAV Airflow Calibration without Down-Duct Static Control – One TAB project which troubled me for quite some time was performed under extreme schedule commitment duress. The project involved three large buildings which formed a complex. Each building had 5 levels with 20-30 VAVs per level and a dedicated Air Handling Unit (AHU) for each level. The BAS contractor was struggling to complete his scope of work as we began TAB at the zone level. Despite the lack of down-duct static control, we attempted to execute our scope of work by closing $\frac{1}{2}$ of the VAVs on a given floor to build down duct static for other VAVs on that floor. Our plan to determine the required down-duct static pressure setpoint as well as the “Hydraulically-Hardest-to-Satisfy” VAV involved time at the end of the project at the BAS Operator Work Station (OWS). We would configure the VAVs of each AHU to provide full demand at the AHU design CFM. We could then modify the down-duct static pressure setpoint until one or more VAVs were close to 100% open. This would identify the hydraulic-hardest-to-satisfy VAV as well as the optimal static pressure setpoint. AHU Minimum Outside Air could be set followed by measurement and documentation of fan final operational data in our TAB report. Armed with this plan, we did not worry about damper positions as we proceeded through the facility. We did notice that we were calibrating Minimum airflow with the dampers 5 to 15% open and Maximum airflow with dampers only 20-30% open.

When VAV calibration and outlet proportional balancing had been completed and AHU down-duct static pressure control was operational on all units, I returned to execute the final stage of

the process. Determining static setpoints and identifying the hydraulically-hardest-to-satisfy terminal units on each AHU required close to two full days. After the setpoint was determined, it was amazing how open the VAVs appeared on the BAS when set to provide Maximum airflow. Very few were less than 70-80% open. When the setpoint operation was complete, I proceeded to verify zone level airflow in Minimum and Maximum modes of operation was unaffected and we could proceed to fan final operational testing. Imagine my chagrin when practically EVERY VAV I checked was either higher or lower than design airflow by 20-30%. For the TAB report to be accurate, we had to adjust the BAS correction factor for each VAV and re-measure each zone in Minimum mode as well.

The Realization: Duct Static and VAV Damper Position REALLY Matter!

These and other observations and experiences have convinced me that the phenomenon of VAV airflow inaccuracy AFTER calibration has occurred is only a significant problem when two operational factors are simultaneously present during calibration:

- VAV Damper positions at calibration vary significantly from where they will operate...
- ...Duct static upstream of VAV damper (Duct where airflow sensor is located) is significantly different from pressure the VAV will normally operate at.

The movement of air molecules through a duct and across the airflow sensor is similar to the movement of automobile traffic on a highway, **Figure 6**.

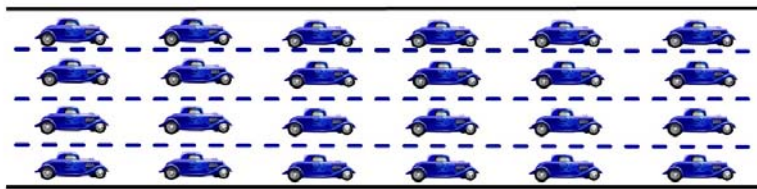
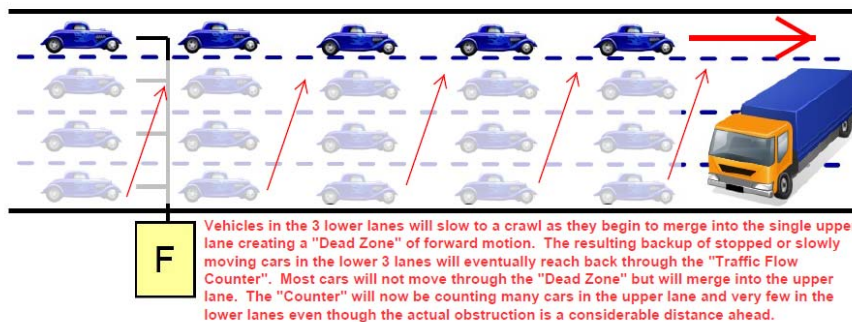

Figure 6: Traffic on Highway Moving Without Problems

As lanes on a highway are closed, cars attempt to move around the obstruction. The distance the traffic backs up depends on the number of drivers on the road. If traffic is heavy, stagnation in the affected lanes can reach astounding distances before the obstruction, **Figure 7**.



F= Traffic Flow Counter

Figure 7: Traffic on Highway Moving Past Flow Obstruction

Air molecules do not change direction abruptly upon encountering an obstruction. The resulting “Turbulence” when air encounter an obstruction builds a dynamic pattern which resists changes in air movement. As the pressure or number of air molecules in the Supply duct increases, the VAV damper closes, forcing air molecules to move around the obstruction through the edges of the VAV damper at very high velocities. All air molecules must change direction to move around the turbulent area in front of the closed damper. The resulting air “backup” can extend beyond the VAV airflow sensor. This changes the pattern and average ΔP across sensor to the VAV DPT as depicted in **Figure 8**.

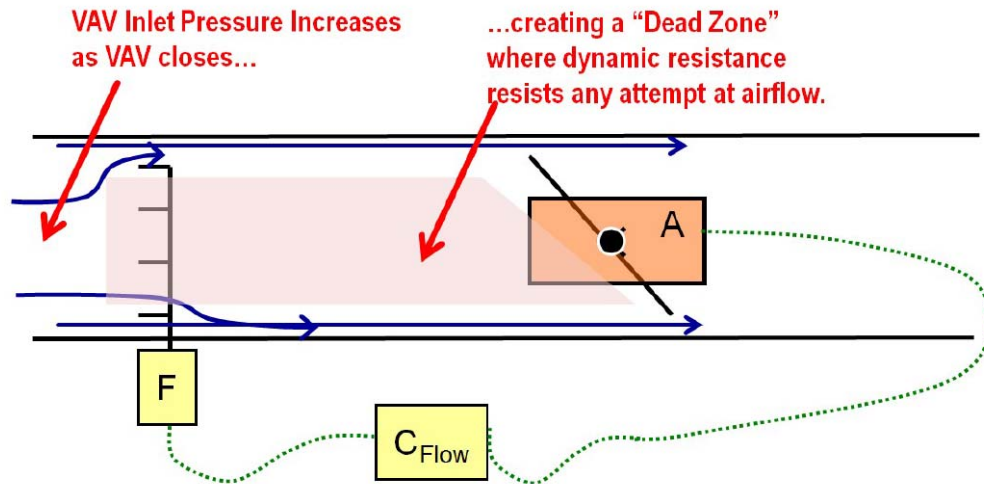

Figure 8: Effect of Significantly Closed VAV Damper on Airflow Patterns

To avoid issues of this nature, the VAV inlet duct static pressure during airflow calibration must be maintained near future operational level. If the inlet static is extremely high during TAB calibration, the VAV damper will be significantly closed. Similarly, if the VAV inlet static is very low, the VAV damper will be almost completely open during calibration. In either case, VAV calibration at one damper position with a given inlet duct static pressure followed by operating VAV damper positions and inlet duct static significantly different from the calibration value appears to invite system operational issues and energy waste.

Section 4 – Example from Medical Research Facility RCx

The good news for Cx and RCx personnel is that there can be considerable energy savings and improvements in system performance if this issue is identified and resolved on your project. The following example is from an RCx project in a Medical Research Facility. For this example we consider only one VAV on a single AHU. The AHU operates with a Hot and Cold Deck. The air to the zones is supplied through 62 Dual Duct, Pressure Independent VAV terminal units.

After a site walk through the zones and the Mechanical Room containing the AHU, we began to evaluate zone performance using the BAS. The actual evaluation process described here is significantly abbreviated but the basic framework of the process we followed is intact.

Dual Duct VAV Performance Issues

The entire facility had been rebalanced 6-months prior to the RCx effort. We had a copy of the TAB Report in hand as we evaluated the systems through the BAS. **Figure 9** is an example of a typical Dual Duct VAV on the project. The first item noticed was that the sum of Hot and Cold Duct airflow setpoints didn't match Discharge airflow setpoint (1777 CFM vs. 1800 CFM). It was also intriguing that the total airflow setpoint, 1810 CFM, varied from the design of 3,015 CFM listed in the TAB report design as well as the TAB documented airflow of 2380 CFM. Facility engineering and maintenance personnel were unaware that current airflow requirements varied from design and TAB airflow. This was common with most VAVs supplied by this AHU.

As we were investigating this "Design/Calibration/As-Found airflow" discrepancy, we noticed that the TAB report contained documentation of calibration and testing at Maximum airflow only instead of Maximum AND Minimum (Design of 3,015 and 955 CFM respectively). The reason for omitting Minimum airflow mode measurements was not explained in the TAB report.

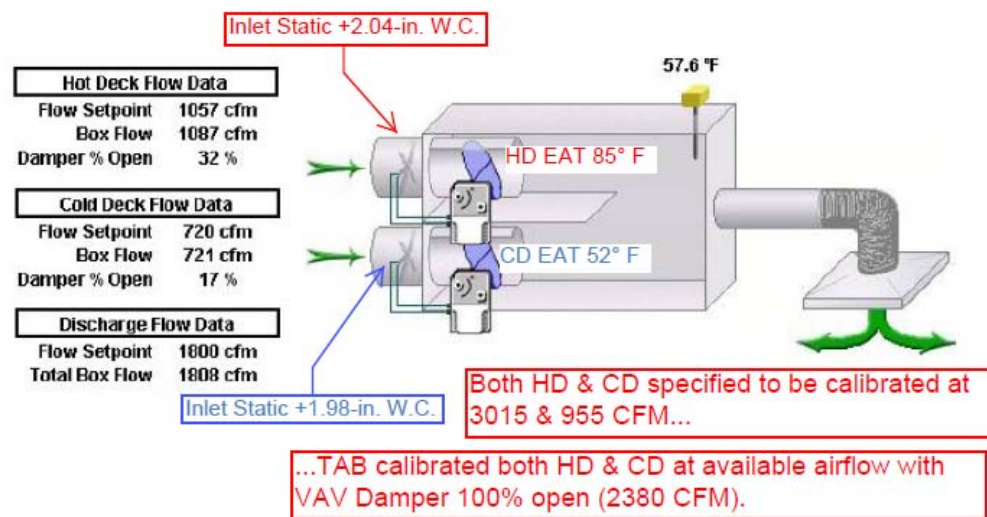

Figure 9: VAV Example of Airflow Operational Issues

Another item of interest in **Figure 9** was the apparent DAT of 57.6° F. When compared to the Hot and Cold duct Entering Air Temperature (EAT) and airflow, this value appeared suspicious. Mathematical verification determined that if the BAS airflow for HD & CD were correct, the BAS DAT should display "71.8° F" as calculated below.

$$\text{DAT} = [(\text{HD CFM} / \text{Total CFM}) * \text{HD EAT}] + [(\text{CD CFM} / \text{Total CFM}) * \text{CD EAT}]$$

$$[(1,087 \text{ CFM} / 1808 \text{ CFM}) * 85^\circ \text{ F}] + [(721 \text{ CFM} / 1808 \text{ CFM}) * 52^\circ \text{ F}] = \mathbf{71.8^\circ \text{ F}}$$

Many VAVs appeared to have similar issues.

We selected 4 VAVs at random (including the VAV in **Figure 9**) to test zone level operation. The following items were measured and observed to compare with BAS indication:

- The BAS DAT sensor calibration was accurate within ½° of a calibrated instrument.
- The discharge air temperature (DAT) sensor location was optimal for accurate mixed air temperature measurement.
- The accuracy of the BAS displayed Hot and Cold Duct “Damper % Open” was verified; Both Hot and Cold VAV dampers were considerably closed as shown in **Figure 9**.
- Hot VAV inlet duct static was measured at +2.04-in. W.C.
- Cold VAV inlet duct static was measured at +1.98-in. W.C.

We configured the VAV to flow air completely through the 14-inch Hot Duct at the “As-Found” BAS Maximum setpoint of 1,800 CFM and then reset the airflow setpoint to the specified design Minimum 955 CFM. The inlet duct was traversed and HD airflow sensor ΔP measured at both Maximum and Minimum airflow. The results are summarized in **Table 1** and on the VAV inlet duct airflow sensor chart in **Figure 10**.

Table 1: VAV Hot Deck Airflow

Mode of Operation	BAS	Duct Traverse	Actual% of BAS
Maximum Airflow	1,835	1,962	107%
Minimum Airflow	963	1,125	117%

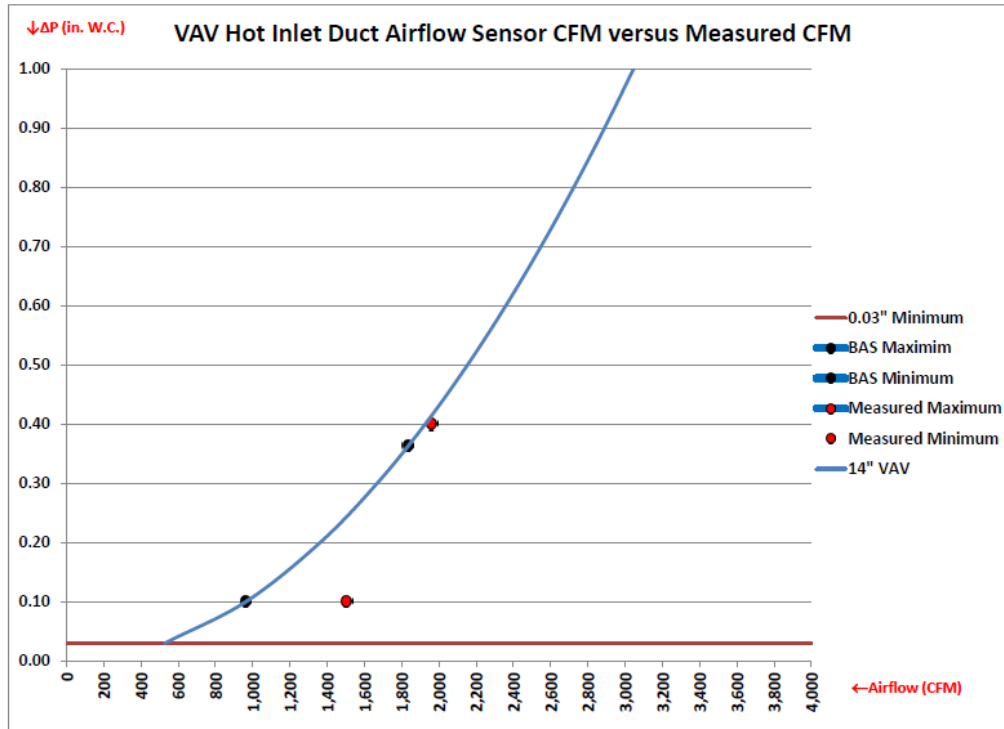

Figure 10: VAV Hot Inlet Duct Airflow Measurements

Tests were made of the Cold VAV using the same airflow setpoints. The Hot and Cold ducts of the additional 3 VAVs selected at random were also tested using the same methodology with very similar results.

Based on these measurements and observations, we suspected VAV airflow sensor calibration errors had occurred to many if not all of the VAVs served by this AHU. To verify or refute this suspicion we measured airflow in three separate manners:

1. Coil traverses of the AHU Hot Deck & Cold Deck coils.
2. Individual Supply duct traverses, 4 from the Hot Deck, 4 from the Cold Deck.
3. Measured and documented Supply Fan operational data (RPM, static pressure, voltage, amperage) to plot on the fan performance curve.

Comparison of fan airflow measured in all three cases indicated a discrepancy of 2% between the most extreme values. This is well within boundaries of acceptable instrument error. Comparison of the measured airflow values with the sum of individual VAV airflow as displayed at the OWS indicated that actual Hot Deck airflow was 122% of the BAS while actual Cold Deck airflow was 118% of the BAS airflow summary. The facility AHUs are never allowed to shut down meaning this AHU was providing 120% of the required conditioned air to the medical laboratory facility 24 hours each day, 365 days each year.

The obvious benefits to be realized by addressing this airflow discrepancy across the entire AHU is the reduction from an 83% reduction in overall airflow as well as a reduction in Down-Duct Static Pressure is incredible from an electrical consumption status. The 2 Supply fans operate with a combined 46-BHP. In addition however we must consider the energy required at the Central Plant to produce and distribute Chilled Water to the Cold Deck. The Central Plant also produces Steam for the Hot Deck coil to condition the air to the Hot Ducts of the Dual Duct VAVs. Due to the fact that the AHU serves research laboratories, the air through this AHU is completely from Outdoors (100% Outside Air). The reduction in energy savings associated with 17% less air to dehumidify, cool and heat is of significant value to the bill paying customer. Zone occupants who constantly complained of Cold or Heat along with air noise will also derive great benefit from airflow & static pressure reduction due to a VAV re-calibration effort.

Section 5 – Addressing VAV Calibration Issues

The following points may sound ambitious and unrealistic but the magnitude of this issue demands more attention. While pervasive, the phenomenon remains for the most part unrecognized and I believe, under-valued. As far as I have observed, inaccuracy of VAV airflow is one of the last items questioned until noise or temperature extremes in the zone force the issue to the forefront. Unless Cx professionals understand the causes and costs of this phenomenon and how to avoid the issue, other HVAC professionals are unlikely to expend the effort necessary to effectively address and resolve these problems. Accountability must be demanded of industry participants. The following are some thoughts that may prove of value in this direction.

Educate MEP, TAB and Cx Personnel about this Phenomenon

TAB personnel are under extreme duress to complete construction projects. Not only are they required to perform their scope of work in an accelerated and often unrealistic timeline, they are often directed to work without or around HVAC system control and/or performance deficiencies which are necessary to complete their scope of work. As long as project deadlines are the overriding project priority, premature and often incomplete TAB of VAV systems will continue.

While accurate calibration may not be possible in both Maximum and Minimum airflow mode, it should not be acceptable by TAB certification organizations or specifying engineers for TAB personnel to neglect airflow measurement in Minimum mode of operation. As demonstrated earlier, simply documenting the BAS Minimum airflow quantity without an actual measurement is likely to result in significant error.

Cx personnel unaware of potential VAV airflow issues cannot support TAB personnel when pressure is applied. This pressure is applied in the form of demands for premature TAB activity in complete disregard for actual system readiness. Cx personnel who are ignorant of this topic cannot inform their customers of the perils associated with moving ahead performing project activity that may compromise future performance and energy use in their facilities.

BAS Designers Supply Additional VAV Airflow Calibration Points

Several BAS software packages contain multiple calibration points but this is not the normal approach. Most current BAS software contains a single “Calibration” factor applied at Maximum CFM mode of operation. This is understandable as energy waste would be higher if the Maximum airflow were inaccurate but industry experts should understand that while energy use at un-calibrated Minimum airflow may be less than at un-calibrated Maximum airflow, it is by no means negligible. In some extreme cases, inaccurate airflow may be experienced at every airflow setpoint other than Maximum mode.

Request ASHRAE Standard 130-2008 Data from VAV Manufacturers

Performing and publishing test results of *ASHRAE Standard 130-2008* (Specifically Section 5.6) would give the discerning HVAC system design team yet another tool to properly select VAVs.

Conclusion

Addressing this issue is not a “Silver Bullet” for energy savings on VAV systems. There remains more to know about challenges presented to operation of HVAC system by pressure independent VAV terminal units. While the use of these components has become commonplace, they are not entirely self-reliant. They remain susceptible to potentially erroneous and wasteful operation if not initially calibrated in a thorough manner or the AHU system supplying air to the VAV is not controlled at acceptable parameters. Investigation by industry experts would help enormously in the quest for reliable, robust and repeatable VAV performance.