



BELT DRIVE

- CENTRIFUGAL (BISW, AFSW, BIDW, AFDW)
- INDUSTRIAL PROCESS (IPA, IPO, IPW)
- PLENUM (PLN)
- PLUG (PLG)

Installation Operating and Maintenance Manual



CENTRIFUGAL AND INDUSTRIAL



PLUG



PLENUM

TABLE OF CONTENTS

GENERAL INFORMATION	2	Radial Gap Overlap & Wheel Alignment	6-7
Handling	2	V-Belt Drives	7
Storage	2	UNIT START-UP	8
Unit Identification	2	Additional information	8
Caution	3	Vibration	9
INSTALLATION	3	ROUTINE MAINTENANCE	9
Centrifugal conditions	3-4	Motors	9
Plenum / Plug conditions	5	Bearings	10
Belt Guards	5	V-Belt Drive	10
Bases	6	TROUBLESHOOTING	11
Rotatable Housing	6	WARRANTY	12

Report any damaged equipment to the shipper immediately!

All Centrifugal, Industrial Process, Plenum and Plug Fans are shipped on a skid or packaged to minimize damage during shipment. The transporting carrier has the responsibility for delivering all items in their original condition as received from Greenheck. The individual receiving the equipment is responsible for inspecting the unit for obvious or hidden damage, recording any damage on the bill of lading before acceptance and filing a claim (if required) with the final carrier.

GENERAL INFORMATION

To insure a successful installation, the instructions in this manual should be read and adhered to. Failure to comply with proper installation procedures may void the warranty.

HANDLING

Fans are to be rigged and moved by the lifting brackets provided or by the skid when a forklift is used. See figures below for proper lifting locations. Location of brackets varies by model and size. Handle in such a manner as to keep from scratching or chipping the coating. Damaged finish may reduce ability of fan to resist corrosion.

FANS SHOULD NEVER BE LIFTED BY THE SHAFT, HOUSING, MOTOR, BELT GUARD OR ACCESSORIES.

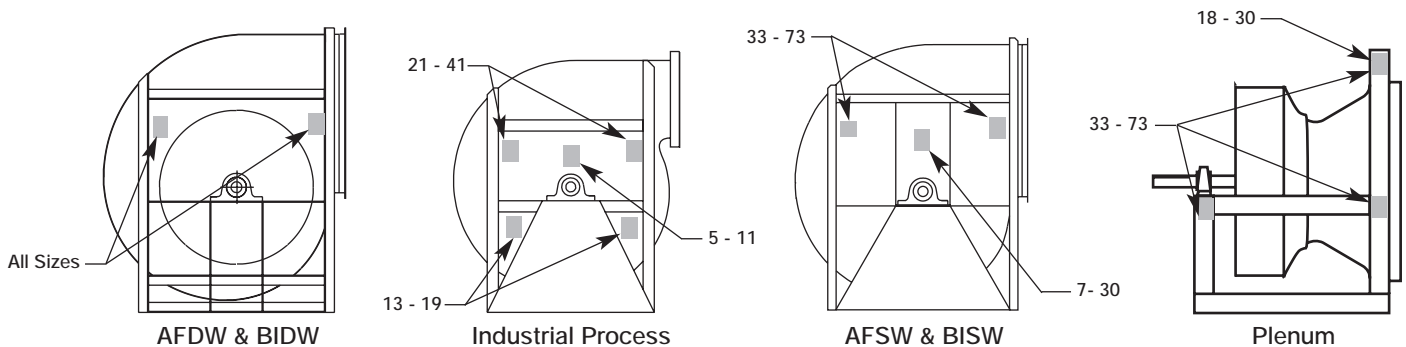

STORAGE

When a fan is not going to be in service for an extended amount of time, certain procedures should be followed to keep the fan in proper operating condition.

- Rotate fan wheel monthly and purge bearings once every three months
- Cover unit with tarp to protect from dirt and moisture (Note: do not use a black tarp as this will promote condensation)
- Energize fan motor once every three months
- Store belts flat to keep them from warping and stretching
- Store unit in location which does not have vibration
- After storage period, purge grease before putting fan into service

If storage of fan is in a humid, dusty or corrosive atmosphere, rotate the fan and purge the bearings once a month. Improper storage which results in damage to the fan will void the warranty.

UNIT IDENTIFICATION

The tag below is an example of an identification label on the fan. The information provides general details about the fan, as well as containing specific information unique to the unit. When contacting your Greenheck representative with future needs or questions, please have the information on this label available.

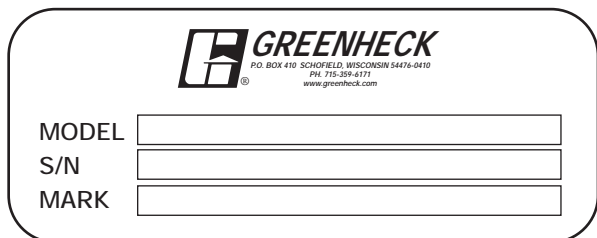

Tags are mounted in an area which is clearly visible, usually near the fan outlet on the drive side of the fan. The exact tag location may differ due fan model and size.

Typical mounting locations for identifying tags

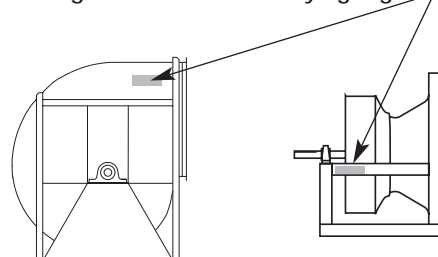

- Model - General description of fan
- S/N - Serial Number assigned by Greenheck, which is a unique identifier for every unit
- Mark - Customer supplied identification

CAUTION!

When installing a fan, ensure the proper protective devices are used to protect personnel from moving parts and other hazards. A complete line of protective accessories are available from Greenheck including: inlet guards, outlet guards, belt guards, shaft guards, protective cages and electrical disconnects.

Check local codes to ensure compliance for all protective devices.

For further details on safety practices involving industrial and commercial fans please refer to AMCA Publication 410.

ELECTRICAL DISCONNECTS

All fan motors should have disconnects located in close visual proximity to turn off electrical service. Service disconnects shall be locked out when maintenance is being performed.

MOVING PARTS

All moving parts must have guards to protect personnel. Refer to local codes for requirements as to the number, type and design. Fully secure fan wheel before performing any maintenance. The fan wheel may start "free wheeling" even if all electrical power has been disconnected. Before the initial start-up or any restart, check the following items to make sure that they are installed and secure.

GUARDS (BELT, SHAFT, INLET, OUTLET)

Do not operate fans without proper protective devices in place. Failure to do so may result in serious bodily injury and property damage.

ACCESS DOORS

Before opening access doors ensure the fan wheel has stopped moving and that the wheel has been secured from being able to rotate. Do not operate fan without access door in its fully closed position.

AIR PRESSURE AND SUCTION

In addition to the usual hazards associated with rotating machinery, fans also create a dangerous suction at the inlet. Special caution needs to be used when moving around a fan whether it is in operation or not. Before start-up, make sure the inlet area is clear of personnel and loose objects.

INSTALLATION

Installations with inlet or discharge configurations that deviate from this standard may result in reduced fan performance. Restricted or unstable flow at the fan inlet can cause pre-rotation of incoming air or uneven loading of the fan wheel yielding large system losses and increased sound levels. Free discharge or turbulent flow in the discharge ductwork will also result in system effect losses. Refer to the following diagrams for the most efficient installation conditions.

CENTRIFUGAL AND INDUSTRIAL PROCESS FANS - INSTALLATIONS

DUCTED INLET INSTALLATIONS

Inlet Duct Turns

Installation of a duct turn or elbow too close to the fan inlet reduces fan performance because air is loaded unevenly into the fan wheel. To achieve full fan performance, there should be at least one fan wheel diameter between the turn or elbow and the fan inlet.

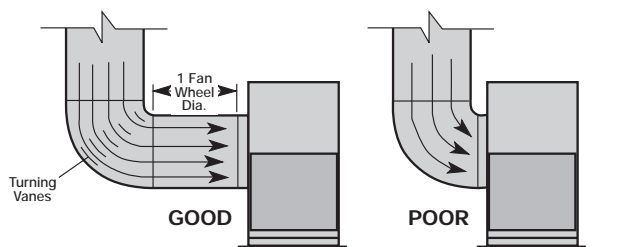

Inlet Spin

Inlet spin is a frequent cause of reduced fan performance. The change in fan performance is a function of the intensity of spin and not easily defined. The best solution is proper duct design and airflow patterns.

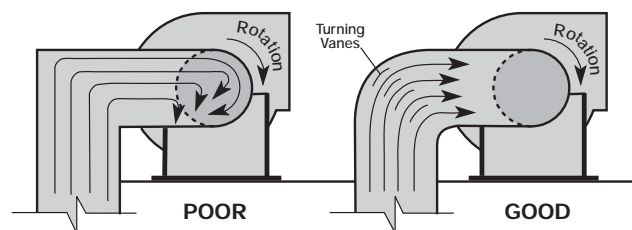

DUCTED OUTLET INSTALLATIONS

Discharge Duct Turns

Duct turns located near the fan discharge should always be in the direction of the fan rotation.

Fan performance is reduced when duct turns are made immediately off the fan discharge. To achieve cataloged fan performance there should be at least three equivalent duct diameters of straight ductwork between the fan discharge and any duct turns.

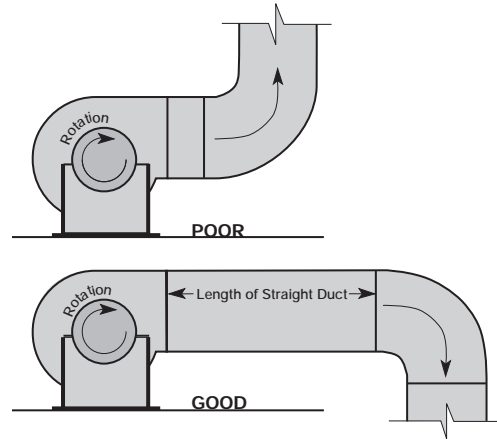

NON-DUCTED INSTALLATIONS

Non-Ducted Inlet Clearance

Installation of a fan with an open inlet too close to a wall or bulkhead will cause reduced fan performance. It is desirable to have one fan wheel diameter and a minimum of three-fourths of a wheel diameter between the fan inlet and the wall.

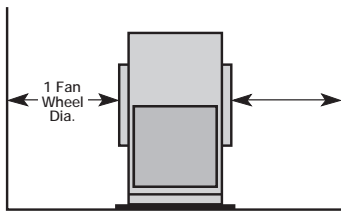

Free Discharge

Free or abrupt discharge into a plenum results in a reduction in fan performance. The effect of static regain in discharge is not realized.

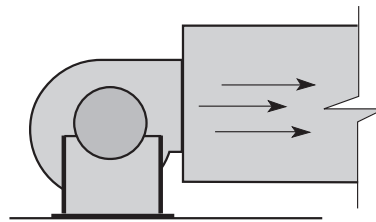

CENTRIFUGAL - Outdoor Installation for UL 762 Listed Fans for Restaurant Exhaust

The UL 762 listing for restaurant exhaust is available on BISW fan sizes 7- 73, Arr. 1 and 9 with belt guard and Arr. 10 with weatherhood. UL 762 fans are listed for a maximum operating temperature of 375°F and include a bolted access door and 1" drain connection. An outlet guard is strongly recommended when the fan discharge is accessible. An upblast discharge is recommended. The fan discharge must be a minimum of 40" above the roof line and the exhaust duct must be fully welded to a distance of 18" above the roof surface.

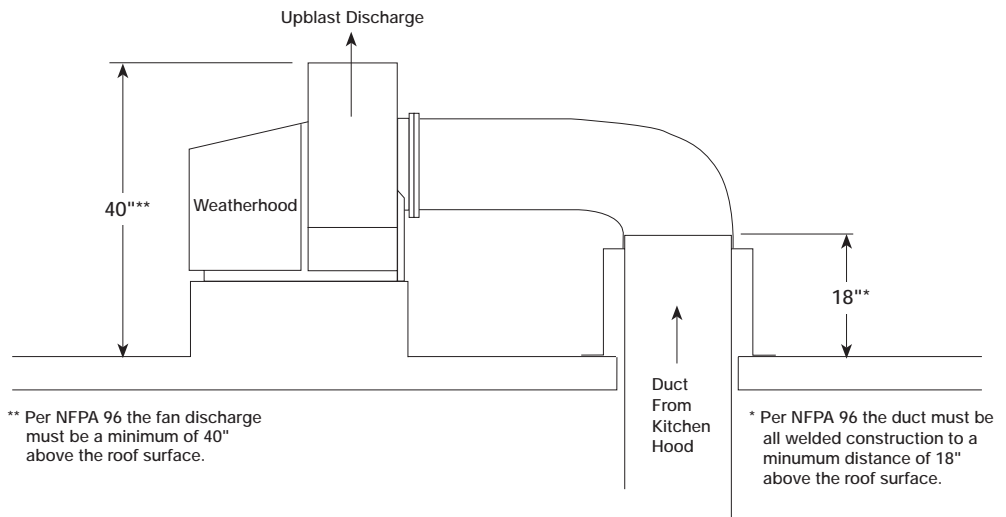

This drawing is for dimensional information only. See the latest edition of NFPA 96 Standard for Ventilation Control and Fire Protection of Commercial Cooking Operations for detailed installation instructions, materials, duct connections and clearances.

PLENUM AND PLUG FANS - INSTALLATIONS

UNHOUSED WHEELS

Adjacent Walls

The distance between the fan and walls or ceilings will effect the performance of the fan. The recommended distance between the fan wheel and any wall is a minimum of one - half wheel diameter. Multiple walls reduce the performance even more.

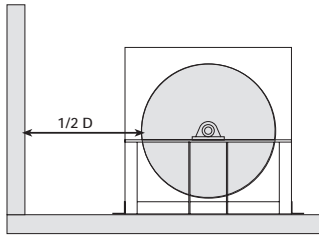

Side by Side

When two or more plenum fans are in parallel, there should be at least one fan diameter spacing between the wheels. Applications with less spacing will experience performance losses.

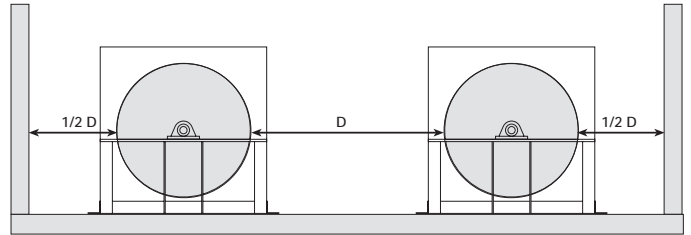

BELT GUARDS

Greenheck offers four types of customized belt guards dependent upon fan model, arrangement and motor position. The four types of belt guards are shown in illustrations to the right.

If the guard is not purchased from Greenheck, they must be supplied by the installer or owner.

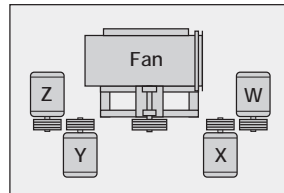

Motor position and fan rotation are determined from drive side

Type 1

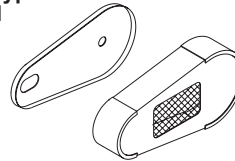

PLN & SW - Arr. 1, 3
(Mtr. Pos. W/Z)
SW - Arr. 9, 10
PLG

Type 3

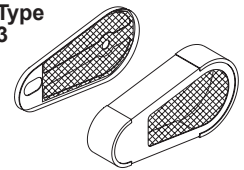

DW - Arr. 3
(Mtr. Pos. W/Z)

Type 2

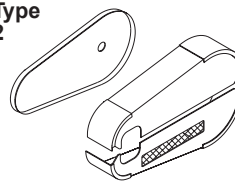

PLN & SW - Arr. 1, 3
(Mtr. Pos. X/Y)

Type 4

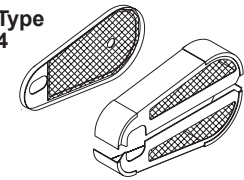

DW - Arr. 3
(Mtr. Pos. X/Y)

If the belt guard is not factory mounted or was not supplied by Greenheck, then it must be field mounted. **Brackets and mounting hardware are the responsibility of the installer.** The figures below illustrate suggested attachment points for belt guard mounting bracket locations. These locations vary with motor mounting position, arrangement, and fan type. The bearing supports and fan structure are used in most instances and when the motor is not mounted to the fan itself, a bracket should also be located near it. This information is intended as only a guide and actual field conditions may dictate another mounting location for the guard brackets. Refer to local codes for securing guarding.

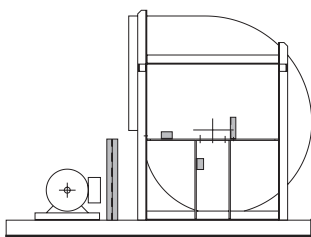

Mtr. Position: W/Z
Arr. - 1,3

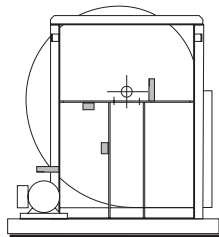

Mtr. Position: X/Y
Arr. - 1,3

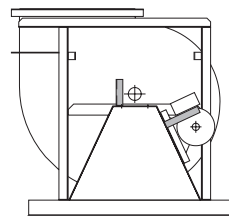

Mtr. Position: L/R
Arr. - 9

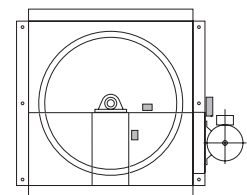

Mtr. Position: Slide

Suggested Attachment Points

BASES

(FOUNDATION AND ISOLATION)

Critical to every fan installation is a strong, level foundation. A reinforced poured concrete pad with a structural steel base or inertia base provides an excellent foundation. Structural bases must be sturdy enough, with welded construction, to prevent flexing and vibration.

To eliminate vibration and noise from being transferred to the building, vibration isolators should be used. The fan is mounted directly on the isolation base and must be supported the entire length of the fan base angle (Refer to the installation manual for structural bases if the base was supplied by Greenheck). The isolators are installed between the isolation base and the foundation.

After the fan, isolation base, and isolators are installed, the entire assembly must be leveled. Position the level on the isolation base, not the fan shaft, for proper leveling. Additionally, the motor and fan shafts must be level and parallel relative to each other for proper alignment.

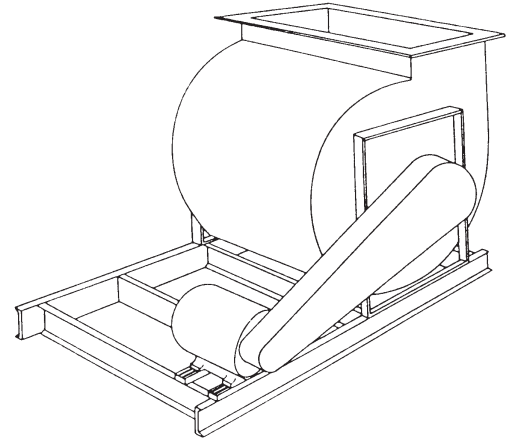

Typical Fan on Isolation Base

ROTATABLE HOUSINGS

It may be necessary to rotate the scroll of the fan to achieve a different discharge position than what was originally supplied. Centrifugal fans models BISW, AFSW, BIDW, and AFDW (sizes 7 - 30, arr. 1, 9, and 10, class I and II) and Industrial Process fans (sizes 5 - 19, standard and heavy duty) have the flexibility to be rotated in the field. This is accomplished by removing the housing bolts, rotating the housing to a new discharge position, and reinstalling the bolts.

RADIAL GAP, OVERLAP & WHEEL ALIGNMENT

Efficient fan performance can be maintained by having the correct radial gap, overlap and wheel alignment. These items should be checked after the fan has been in operation for 24 hours and before start-up when the unit has been disassembled. Radial gap and overlap information applies to models: BISW, AFSW, BIDW, AFDW, PLN, and PLG.

Inlet Cone to Backplate Distance (inches)

Unit Size	A dim. ± Tolerance	
7 - 10	3 5/8	± 1/8
12	4	± 1/8
13	4 7/16	± 1/8
15	5	± 1/8
16	5 7/16	± 1/8
18	6 3/8	± 1/8
20	7	± 3/16
22	7 13/16	± 3/16
24	8 5/8	± 1/4
27	9 7/16	± 1/4
30	10 9/16	± 3/8
33	11 7/16	± 3/8
36	12 3/4	± 3/8
40	14 3/16	± 3/8
44	15 9/16	± 3/8
49	17 1/8	± 1/2
54	18 13/16	± 1/2
60	20 15/16	± 1/2
66	22 7/8	± 1/2
73	25 1/2	± 1/2

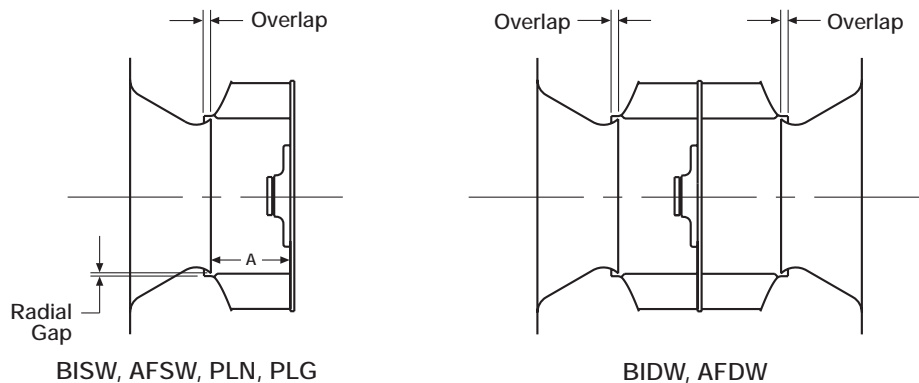

RADIAL GAP

Radial gap is adjusted by loosening the inlet cone/ring bolts and centering the cone/ring on the wheel. If additional adjustment is required to maintain a constant radial gap, loosening the bearing bolts and centering wheel is acceptable as a secondary option.

OVERLAP

Overlap is adjusted by loosening the wheel hub from the shaft and moving the wheel to the desired position along the shaft. The Inlet Cone to Backplate Distance chart lists the distance between the wheel and the inlet cone spacing for non-double width fans. Overlap on double width fans is set by having equal spacing on each side of the wheel.

WHEEL ALIGNMENT

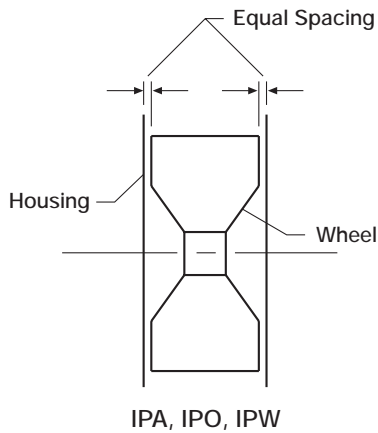

Correct wheel alignment for industrial process fans, models IPA, IPO, and IPW is achieved by centering the wheel in the housing.

V BELT DRIVES

The V-belt drive components, when supplied by Greenheck Fan Corporation, have been carefully selected for this unit's specific operating condition. Caution: changing V-belt drive components could result in unsafe operating conditions which may cause personal injury or failure of the following components: 1. Fan Shaft, 2. Fan Wheel, 3. Bearings, 4. V-belt, 5. Motor.

V BELT DRIVE INSTALLATION

1. Remove the protective coating from the end of the fan shaft and assure that it is free of nicks and burrs.
2. Check fan and motor shafts for parallel and angular alignment.
3. Slide sheaves on shafts - do not drive sheaves on as this may result in bearing damage.
4. Align fan and motor sheaves with a straight-edge or string and tighten.
5. Place belts over sheaves. Do not pry or force belts, as this could result in damage to the cords in the belts.
6. Adjust the tension until the belts appear snug. Run the unit for a few minutes (see section on unit start-up) and allow the belts to "Set" properly.
7. With the fan off, adjust the belt tension by moving the motor base. (See belt tensioning procedures in the maintenance section of this manual). When in operation, the tight side of the belts should be in a straight line from sheave to sheave with a slight bow on the slack side.

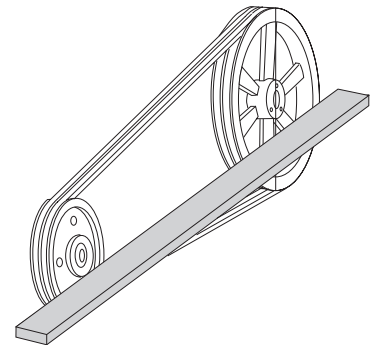

Aligning Sheaves with a Straight Edge

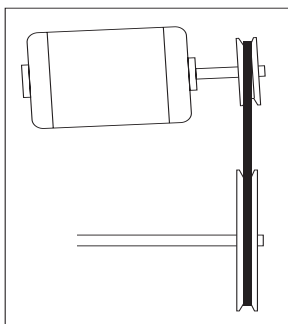

Improper Sheave Alignment

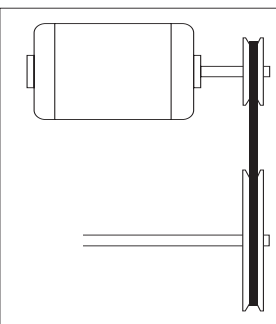
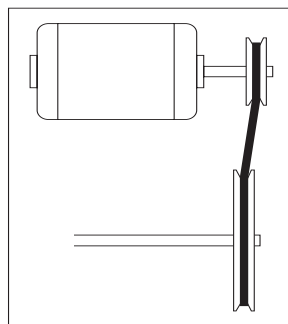

Proper Sheave Alignment

UNIT START UP

1. Disconnect and lock-out all power switches to fan. See warning below.
2. Check all fasteners, set screws and locking collars on the fan, bearings, drive, motor base and accessories for tightness.
3. Rotate the fan wheel by hand and assure no parts are rubbing.
4. Check for bearing alignment and lubrication.
5. Check the V-belt drive for proper alignment and tension.
6. Check the all guarding (if supplied) for being securely attached and not interfering with rotating parts.
7. Check operation of variable inlet vanes or discharge dampers (if supplied) for freedom of movement.
8. Check all electrical connections for proper attachment.
9. Check housing and ductwork, if accessible, for obstructions and foreign material that may damage the fan wheel.

WARNING

Disconnect and secure to the "Off" position all electrical power to the fan prior to inspection or servicing. Failure to comply with this safety precaution could result in serious injury or death.

ADDITIONAL STEPS FOR INITIAL START-UP

1. Check for proper wheel rotation by momentarily energizing the fan. Rotation is always determined by viewing the wheel from the drive side and should correspond to the rotation decal affixed to the unit. One of the most frequently encountered problems with Centrifugal Fans is motors which are wired to run in the wrong direction. This is especially true with 3-phase installations where the motor will run in either direction, depending on how it has been wired. To reverse rotation of a 3-phase motor, interchange any two of the three electrical leads. Single phase motors can be reversed by changing internal connections as described on the motor label or wiring diagram.

CW ROTATION

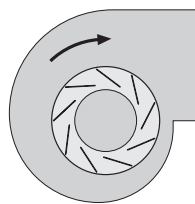

Centrifugal
Backward Inclined

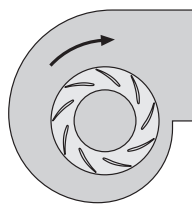

Centrifugal
Airfoil

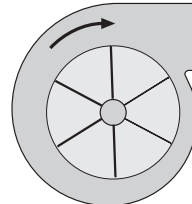

Industrial Process
Radial Blade

Always viewed from the drive side.

2. If the fan has inlet vanes, they should be partially closed to reduce power requirements. This is especially important if the fan is designed for a high temperature application and is being started at room temperature.
3. Fans with multi-speed motors should be checked on low speed during initial start-up.
4. Check for unusual noise, vibration or overheating of bearings. Refer to the "Troubleshooting" section of this manual if a problem develops.
5. Grease may be forced out of the bearing seals during initial start-up. This is a normal self-purging feature of this type of bearing.

VIBRATION

Excessive vibration is the most frequent problem experienced during initial start-up. Left unchecked, excessive vibration can cause a multitude of problems, including structural and/or component failure. The most common sources of vibration are listed below.

1. Wheel Unbalance
2. Drive Pulley Misalignment
3. Incorrect Belt Tension
4. Bearing Misalignment
5. Mechanical Looseness
6. Faulty Belts
7. Drive Component Unbalance
8. Poor Inlet/Outlet Conditions
9. Foundation Stiffness

Many of these conditions can be discovered by careful observation. Refer to the troubleshooting section of this manual for corrective actions. If observation cannot locate the source of vibration, a qualified technician using vibration analysis equipment should be consulted. If the problem is wheel unbalance, in-place balancing can be done providing there is access to the fan wheel. Any correction weights added to the wheel should be welded to either the wheel back (single plane balance) or to the wheel back and wheel cone (two-plane balance).

Greenheck performs a vibration test on all centrifugal fans before shipping. Three vibration readings are taken on each bearing in the horizontal, vertical, and axial directions. The allowable maximum vibration is 0.15 in/sec. peak velocity filter-in at the fan rpm per AMCA standard 204. These vibration signatures are a permanent record of how the fan left the factory and are available upon request.

Generally, fan vibration and noise is transmitted to other parts of the building by the ductwork. To eliminate this undesirable effect, the use of heavy canvas connectors is recommended. If fireproof material is required, Flexweave 1000 - type FN-30 can be used.

ROUTINE MAINTENANCE

Once the unit has been put into operation, a routine maintenance schedule should be set up to accomplish the following:

1. Lubrication of bearings and motor.
2. Variable inlet vanes should be checked for freedom of operation and wear.
3. Wheel, housing, bolts and set screws on the entire fan should be checked for tightness.
4. Any dirt accumulation on the wheel or in the housing should be removed to prevent unbalance and possible damage.
5. Isolation bases should be checked for freedom of movement and the bolts for tightness. Springs should be checked for breaks and fatigue. Rubber isolators should be checked for deterioration.
6. Inspect fan impeller and housing looking for fatigue, corrosion, or wear.

When performing any service to the fan, disconnect the electrical supply and secure fan impeller.

CAUTION:

When operating conditions of the fan are to be changed (speed, pressure, temperature, etc.) consult Greenheck to determine if the unit can operate safely at the new conditions.

MOTORS

Motor maintenance is generally limited to cleaning and lubrication. Cleaning should be limited to exterior surfaces only. Removing dust and grease buildup on the motor housing assists proper motor cooling. Never wash-down motor with high pressure spray. Greasing of motors is only intended when fittings are provided. Many fractional motors are permanently lubricated for life and require no further lubrication. Motors supplied with grease fittings should be greased in accordance with the manufacturer's recommendations. When motor temperature does not exceed 104°F (40°C), the grease should be replaced after 2000 hours of running time.

BEARINGS

The bearings for Greenheck fans are carefully selected to match the maximum load and operating conditions of the specific class, arrangement, and fan size. The instructions provided in this manual and those provided by the bearing manufacturer, will minimize any bearing problems. Bearings are the most critical moving part of the fan, therefore special care is required when mounting them on the unit and maintaining them.

Refer to the following chart and the manufacturers instructions for grease types and intervals for various operating conditions. Never mix greases made with different bases. This will cause a breakdown of the grease and possible failure of the bearing.

Recommended Bearing Lubrication Schedule for Greenheck Fans								
Relubrication Schedule in Months*								
Fan RPM	Bearing Bore (inches)							
	1/2 - 1	1 1/8 - 1 1/2	1 5/8 - 1 7/8	1 15/16 - 2 3/16	2 7/16 - 3	3 3/16 - 3 1/2	3 15/16 - 4 1/2	4 15/16 - 5 1/2
To 250	6	6	6	6	6	5	4	3
500	6	6	6	5	4	3	3	2
750	6	5	4	3	3	2	2	1
1000	6	4	3	2	2	1	1	0.5
1250	5	3	2	1	1	0.5	0.5	0.25
1500	5	2	1	1	0.5	0.5	0.25	0.25
2000	5	1	1	0.5	0.25	0.25	0.25	0.25
2500	4	0.5	0.5	0.25	0.25	0.25		
3000	4	0.5	0.25	0.25	0.25			
4000	3	0.25	0.25	0.25	0.25			
5000	2	0.25	0.25	0.25				

* Suggested initial greasing interval is based on 12 hour per day operation and 150 degree F. maximum housing temperature. For continuous (24 hour) operation, decrease greasing interval by 50%.

- If possible relubricate with grease while in operation, without endangering personnel.
- For ball bearings (operating) relubricate until clean grease is seen purging at the seals. Be careful not to unseat the seal by over lubricating.
- For ball bearings (idle) add 1-2 shots of grease up to 2" bore sizes, and 4-5 shots of grease above 2" bore sizes with hand grease gun.
- For roller bearings relubricate with 4 shots of grease up to 2" bore size, 8 shots for 2"-5" bore size, and 16 shots above 5" bore size with hand grease gun.
- Adjust lubrication frequency based on condition of purged grease.
- A high quality lithium base grease conforming to NLGI Grade 2 consistency, such as those listed below, should be used.

MOBILITH SHC 220 TEXACO MULTIFAK AFB2 SHELL ALVANIA #2
 MOBILITH AW2 TEXACO PREMIUM RB EXXON UNIREX N2

WARNING: Lubricate bearings prior to periods of extended shutdowns or storage and rotate shaft monthly to aid in preventing corrosion. If the fan is stored more than three months, the bearings should be purged with new grease prior to start-up.

V-BELT DRIVES

V-belt drives must be checked on a regular basis for wear, tension, alignment and dirt accumulation. Premature or frequent belt failures can be caused by improper belt tension, (either too loose or too tight) or misaligned sheaves. Abnormally high belt tension or drive misalignment will cause excessive bearing loads and may result in failure of the fan and/or motor bearings. Conversely, loose belts will cause squealing on start-up, excessive belt flutter, slippage, and overheated sheaves. Either excessively loose or tight belts may cause fan vibration.

When replacing V-belts on multiple groove drives all belts should be changed to provide uniform drive loading. Do not pry belts on or off the sheave. Loosen belt tension until belts can be removed by simply lifting the belts off the sheaves. After replacing belts, insure that slack in each belt is on the same side of the drive. Belt dressing should never be used.

Do not install new belts on worn sheaves. If the sheaves have grooves worn in them, they must be replaced before new belts are installed.

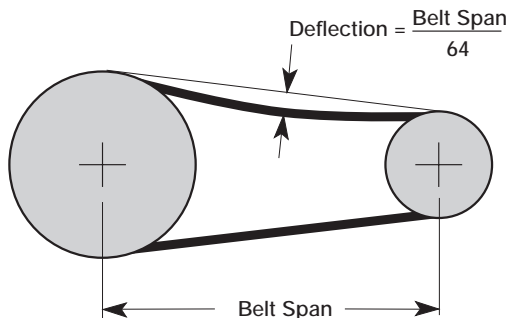

The proper tension for operating a V-belt drive is the lowest tension at which the belts will not slip at peak load conditions. For initial tensioning, the proper belt deflection half-way between sheave centers is 1/64" for each inch of belt span. For example, if the belt span is 64 inches, the belt deflection should be 1 inch using moderate thumb pressure at mid-point of the drive. Check belt tension two times during the first 24 hours of operation and periodically thereafter.

TROUBLESHOOTING

Problem	Cause	Corrective Action
Excessive Noise	Wheel Rubbing Inlet	Adjust wheel and/or inlet cone. Tighten wheel hub or bearing collars on shaft.
	V-Belt Drive	Tighten sheaves on motor/fan shaft. Adjust belt tension. Align sheaves properly (see page 7). Replace worn belts or sheaves.
	Bearings	Replace defective bearing(s). Lubricate bearings. Tighten collars and fasteners.
	Wheel Unbalance	Clean all dirt off wheel. Check wheel balance, rebalance in-place if necessary.
Low CFM	Fan	Check wheel for correct rotation. Increase fan speed.*
	Duct System	See page 3.
High CFM	Fan	Decrease fan speed.
	Duct system	Resize ductwork. Access door, filters, grills not installed.
Static Pressure Wrong	Duct system has more or less restriction than anticipated	Change obstructions in system. Use correction factor to adjust for temperature/altitude. Resize ductwork. Clean filters/coils. Change fan speed.*
High Horsepower	Fan	Check rotation of wheel. Reduce fan speed.
	Duct System	Resize ductwork. Check proper operation of face and bypass dampers. Check filters and access doors.
Fan Doesn't Operate	Electrical Supply	Check fuses/circuit breakers. Check for switches turned off or disconnected. Check for correct supply voltage.
	Drive	Check for broken belts. Tighten loose pulleys.
	Motor	Assure motor is correct horsepower and not tripping overload protector.
Overheated Bearing	Lubrication	Check for excessive or insufficient grease in the bearing.
	Mechanical	Replace damaged bearing. Relieve excessive belt tension. Align bearings. Check for bent shaft.
Excessive Vibration	Belts	Adjust tightness of belts. Replacement belts should be a matched set.
	System Unbalance	Check alignment of shaft, motor and pulleys. Adjustable pitch pulleys with motors over 15 hp motors are especially prone to unbalance. Check wheel balance, rebalance if necessary.

* Always check motor amps and compare to nameplate rating. Excessive fan speed may overload the motor and result in motor failure. Do not exceed the maximum cataloged rpm of the fan.

NOTE: Always provide the unit model and serial numbers when requesting parts or service information.

CENTRIFUGAL / INDUSTRIAL PARTS DRAWING

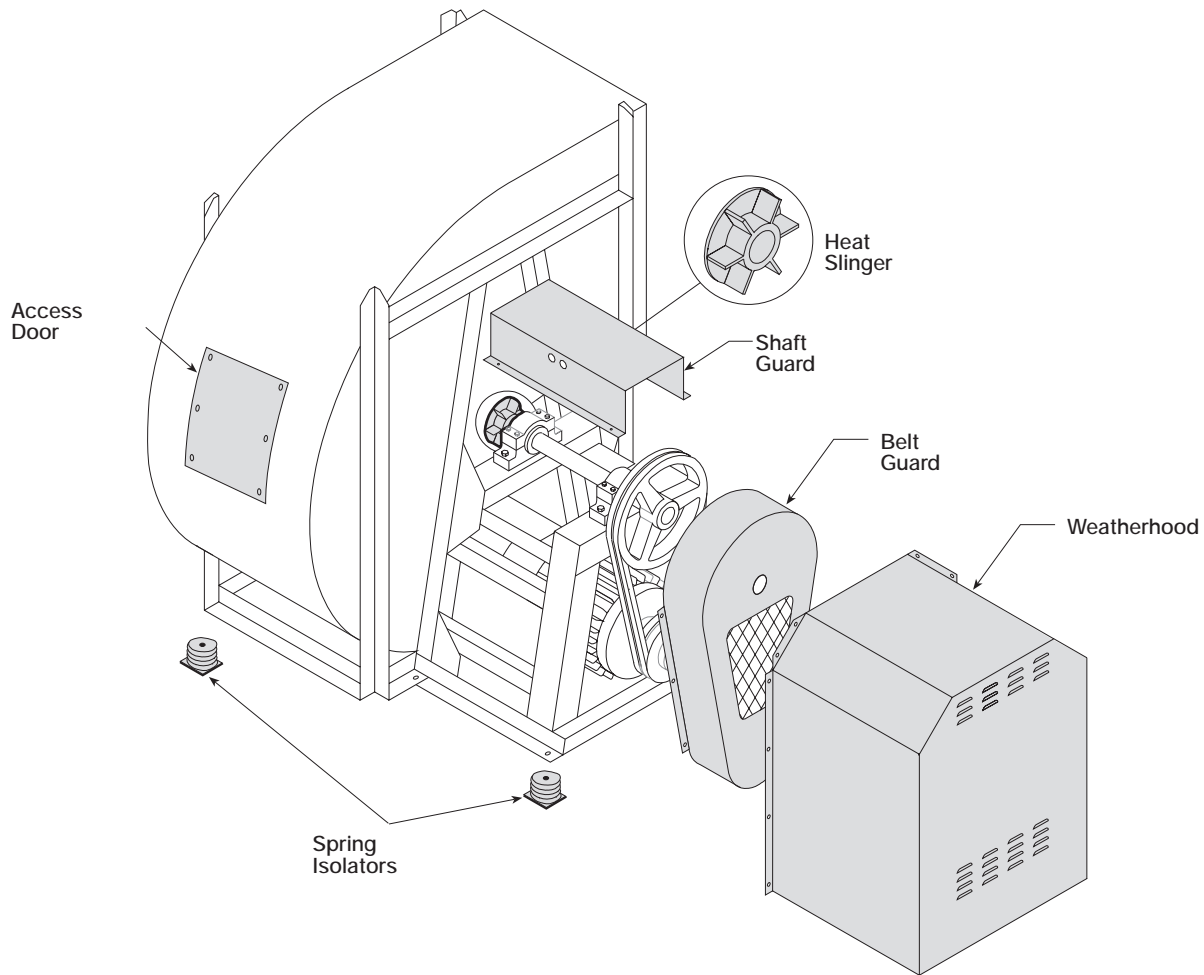

WARRANTY

Greenheck warrants this equipment to be free from defects in material and workmanship for period of one year from the purchase date. This warranty limits our responsibility to repairing or replacing, to the original purchaser, any part or parts of said equipment found to be defective upon examination by representatives of Greenheck. Additionally, said part or parts will be returned to and received by the factory only after prior authorization, with transportation charges prepaid.

Greenheck shall not be obligated under this warranty, for payment of any delivery, removal or installation charges with regard to repair or replacement of any defective part or parts.

Motors are warranted by the motor manufacturer for a period of one year. Should motors furnished by Greenheck prove defective during this period, they should be returned to the nearest authorized motor service station.



GREENHECK

P.O. BOX 410 SCHOFIELD, WISCONSIN 54476-0410

PH. 715-359-6171

www.greenheck.com

IOM CFB FS
Rev. 1
August 1999